

# - FICHE PEF -



Fiche n°5

ENVIRONNEMENT

Pour t'accompagner lors de ce Challenge, voici les licenciés du FC Sourire !



## Jeu 1

avec Paul !

### LA BONNE DÉFINITION !

Paul est à la recherche de la bonne définition pour chaque poubelle ! Aide-le à retrouver le chemin pour chacune en réalisant le slalom !

#### BLAGUE DU JOUR :

Où soigne-t-on les joueurs de football sur le terrain ?



Pour le plastique, le carton et les emballages. Vous pouvez également laisser les bouchons des bouteilles en plastiques.

Destiné au verre, il ne doit pas y avoir de bouchons ou couvercles sur les objets que vous jetez.

Concerne le papier, les journaux, les annuaires, les prospectus etc.

## Jeu 2







avec Fabrice!





### CALCUL DU JOUR!



20



 +  +  = 18  
 +  +  = ....

 -  = ....  
 -  = ....

A = 1 / B = 2... Trouve le mot avec les résultats : ...  
 Pour trouver le mot, le résultat de chaque opération = une lettre de l'alphabet

### Jeu 3

avec Estelle !

### CHARADE !

- Mon 1er fait 365 jours.
- Mon 2ème est le contraire de la mort.
- Mon 3ème est la dernière syllabe de l'euro.
- Mon 4ème est ce que l'on fait avec les lacets
- Mon 5ème est quand on ne dit pas la vérité: Mon tout est ce qui nous entoure.

QUI SUIS -JE : .....

### Jeu 4

avec Paul !

### RÉBUS !

Déchiffre ce rébus pour trouver la phrase écolo !



# Jeu 4

## QUIZZ BALLON/ BUT !

avec Fabrice !

Joue la comme Giroud ! Marque dans le but où se trouve la bonne réponse.

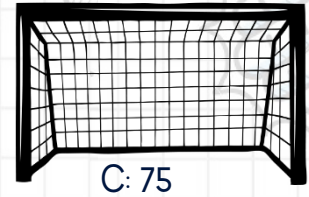
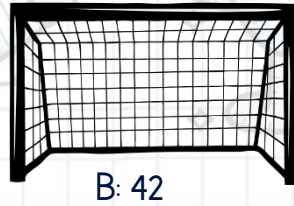
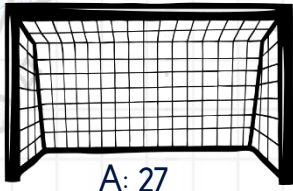

Combien de bouteilles en plastique faut-il pour faire un pull polaire ?

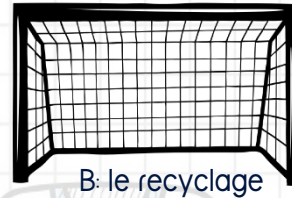
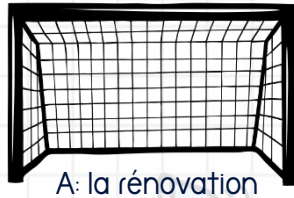

Comment s'appelle l'action qui consiste à donner une nouvelle vie au déchet ?

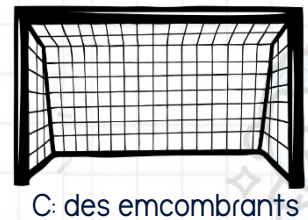

Comment appelle-t-on les gros déchets comme : des réfrigérateurs, des cuisinières, des télévisions ?

QUI ES-TU ?

NOM :

PRÉNOM :

CLUB :

ENTRAÎNEUR :

Nous te donnons rendez-vous pour les prochains challenges !